



Speed Forum and Plugfest Meeting

January 31, 2005

Monday Night

Dana Point, CA

Skip Jones - Chairman

Agenda



Speed Forum Update
Plugfest Update

Skip Jones - Chairman

Speed Forum Update

- Last Con Call 11/5/04
- Last Meeting 12/8/04
- Next Con Call 2/25/05, 9:30AM PDT
- Web Postings
 - Roadmap
 - FAQ
 - Topology Diagram/Terms and Definitions
 - Application Matrix

Skip Jones - Chairman

Fibre Channel Speed Roadmap



Base2*

Product Naming	Throughput (MBps)	Line Rate (GBaud)†	T11 Spec Technically Completed (Year)‡	Market Availability (Year)‡
1GFC	200	1.0625	1996	1997
2GFC	400	2.125	2000	2001
4GFC	800	4.25	2003	2005
8GFC	1600	8.5	2006	2008
16GFC	3200	17	2009	2011
32GFC	6400	34	2012	Market Demand
64GFC	12800	68	2016	Market Demand
128GFC	25600	136	2020	Market Demand

Base10**

10GFC	2400	10.52	2003	2004
-------	------	-------	------	------

***Base2** used throughout all applications for Fibre Channel infrastructure and devices. Each speed maintains backward compatibility at least two previous generations (I.e., 4GFC backward compatible to 2GFC and 1GFC)

****Base10** commonly used for ISLs, core connections, and other high speed applications demanding maximum bandwidth

†**Line Rate:** All speeds are single-lane serial stream

‡**Dates:** Future dates estimated

Skip Jones - Chairman

FAQ



What is meant by “Market Availability”

What is meant by “Technically Complete”

What’s so terrific about “Single Serial Stream”

Skip Jones - Chairman

Fibre Channel App Matrix

	Market	Connection	Length
1	Metro (Optical)	ISL	>= 5km
2	Multi Bldg (Campus) (Optical)	ISL	300m – 5km
3	Single Bldg (Local) (Optical)	ISL	30m – 300m
4	Datacenter or Rack (Optical)	ISL/SEL/BEL	0m – 100m
5	Datacenter or Rack (Copper)	ISL/SEL/BEL	0m – 15m
6	Backplane (Copper)	IDL	0.6m

ISL – Inter-Switch Link
 SEL – SAN Edge Link
 BEL – Back-End Link
 IDL – Inter-Device Link

Skip Jones - Chairman

Physical Topology and Terminology for FC Applications

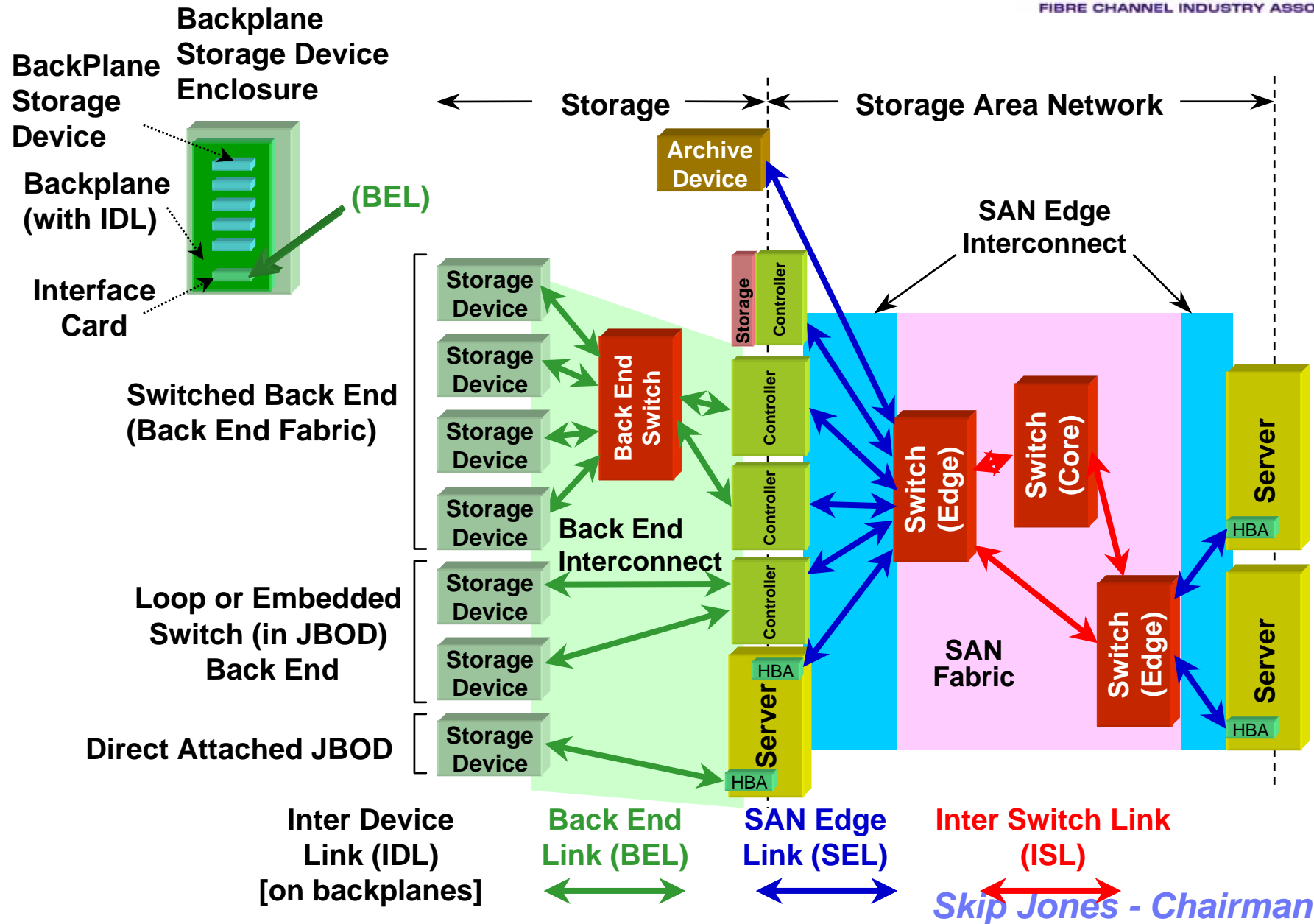

Definitions of devices and nodes

Archive Device – e.g. Tape Device, JBOD, ...

Backplane Storage Devices -

Controller: **Usually located within an enclosure containing storage such as JBOD's or SBOD's. Controllers appear as a target for storage requests from the SAN side (e.g. to host servers). Controllers pass the request as an initiator to the BEL's. Controllers typically contain FC HBA targets and initiator ASIC logic connected through a mezzanine bus such as PCI.**

Fabric: **The collection of switches and associated ISL's in a SAN. Fabrics are commonly shown as a cloud in diagrams.**

HBA - **Host-Bus Adapter: An interface card typically residing in a server that connects the internal bus in the server (e.g., PCI) to the Fibre Channel SAN infrastructure via an SEL**

HDD - **Hard Disk Drive: A storage device typically used in JBOD's**

JBOD - **Just a Bunch of Disks or an enclosure that contains HDD's**

RAID - **Redundant Array of Independent (or Inexpensive) Disks**

SAN - **Storage Area Network: The collection of SEL's, switches, and ISL's that connect servers, controllers, tapes and SAN appliances to each other**

Storage Device – e.g. JBOD, Tape Device, RAID, Media Controller, Translation Device, ...

Storage Enclosure – **Enclosure of Backplane Storage Devices. e.g. JBOD, ...**

Definitions of Links



BEL - Back-End Link:

Connects JBODS, RAID, other storage devices, back-end switches, controller back ends and server back ends using cable assemblies, not backplanes. Technology like SEL, but typically requires shorter links and lower data rates.

BPL - Inter-Device Link:

Backplane interconnect for switch blades, internal switch connections, Blade Servers, ASIC interconnects and related uses. Technology like IDL, but typically requires longer links and higher data rates.

IDL - Inter-Device Link:

Backplane interconnect for storage peripherals

ISL - Inter-Switch Link:

Connects switches to switches

SEL - SAN Edge Link:

Connects edge switches to servers, controllers, or tapes

Skip Jones - Chairman

Notes:



A variant is the collected specifications that allow a link to operate. Variant specifications include encoding scheme, speeds, signal requirements, return loss, etc. Some variants may also include connector and interconnect requirements while others may not. Links only operate under the specifications for a single variant at a time (although some links may have limited variant to variant agility).

Encoding maps with variant, not with speed - 8b10b may be used at any speed supported by a variant, 64b66b may be used at any speed supported by a variant (presently only specified for 10 GFC variants).

A variant may be used in any application (except backplanes, IDL, presently only use electrical variants and distances above approximately 15 meters use only optical variants).

Switches, controllers, and servers all have the capability of having multiple ports where the ports may operate at different speeds (i.e., different variants) in the same switch, controller, or server.

Skip Jones - Chairman

Notes: (Continued)



Controllers and servers contain the Back End Link and SAN Edge Link FC Port function (e.g., HBA).

Switches contain the fabric FC port functions (for both ISL and SEL ports) and may contain BPLs.

If the back end interconnect contains one or more switches the back end interconnect may be called a back end fabric (for portions that are attached to a back end switch). Both BELs and BPLs may be used.

Servers may operate with no SAN edge connections (i.e., only have direct attached storage). This condition has SEL's between the server and the storage but there is no SAN.

Servers may have multiple HBA's with each HBA possibly having multiple ports.

Tapes are directly attached to edge switches (i.e., not behind controllers) because tapes are not collocated with the disks and controllers do not serve any relevant purpose for tapes. Also controllers may interfere with the streaming requirements of tapes

Skip Jones - Chairman



Speed Forum and Plugfest Meeting

January 31, 2005

Monday Night

Dana Point, CA

Skip Jones - Chairman